

KOMSA



Filtro industriale Mini MJC
Per polveri chimiche

MJC Mini

Feature

The MJC Mini filter is a range of compact reverse jet cleaned cartridge filters, suitable for extracting dust from continuous processes. They may operate as free standing filter units complete with hopper and quick release bin, or as open base flanged units for mounting on silos or other vessels.



300 - 3,000 m³/h

- Robust, fully welded steel construction
- Cartridge replacement from clean air side (Top removal)
- UniClean® patented cartridges for maximum efficiency
- Weatherproof for exposed locations
- ATEX compliant for explosion dusts in categories St1, St2 and St3
- Integral pre-separation with down flow/cross flow air distribution
- Wide range of integral fans from 0.75kW to 4.0kW
- Compact dimensions
- Typical air flow volumes up to 3,000 m³/h per single filter unit

Chemical • Mineral • Metallurgy • Welding fume

MJC Mini

How It Works

...during normal operation

1. During normal operation, the dust laden air from the plant travels down the supply duct ①
2. A vertical slotted baffle ② separates the inlet section that slows the airstream and directs dust downward into the hopper, ③ protecting the cartridges from direct abrasion but allowing air to pass horizontally between them.
3. The lighter dust collects on the outside of the filter cartridges ④ as clean air passes through to the inside of each cartridge ⑤. Finally, the clean air travels through the air outlet ⑥ where it could be returned to the plant or exhausted outdoors.
4. The heavier dust settles in the hopper section ③ where it can be discharged into a metal bin ⑦ or through a rotary air lock

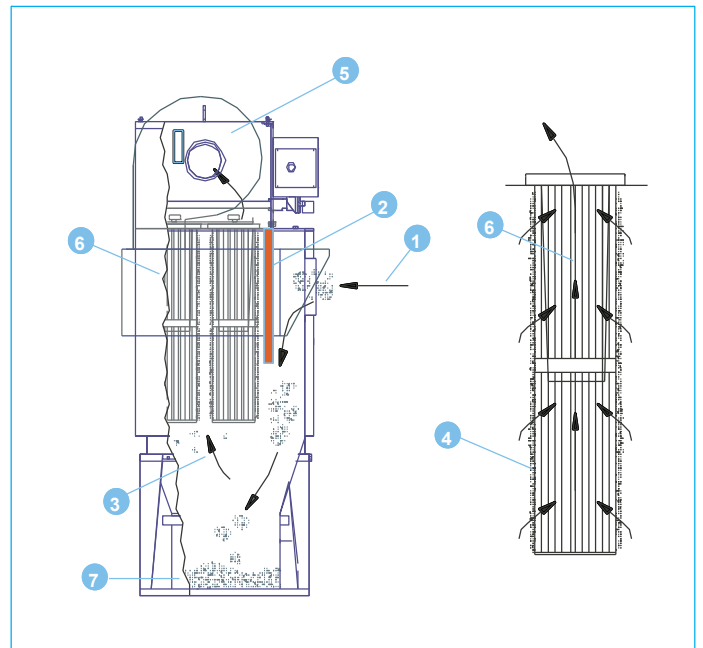

...while cleaning

1. The MJC can utilize a Delta-P gauge to control the compressed air cleaning. In essence, the filter cleans itself when it needs to!
2. A compressed air line must be connected to one end of the compressed air manifold ⑧
3. A solenoid valve opens to allow compressed air from the compressed air manifold into the jet tubes. ⑨ The jet tubes ⑨ are aligned above each row of cartridges. ⑥
4. The downward blast ⑩ blows the dust off the tubular filter bag (from the inside out) ④ where it settles into the hopper section ③ to be collected in the metal bin ⑦ or discharged through a rotary air lock

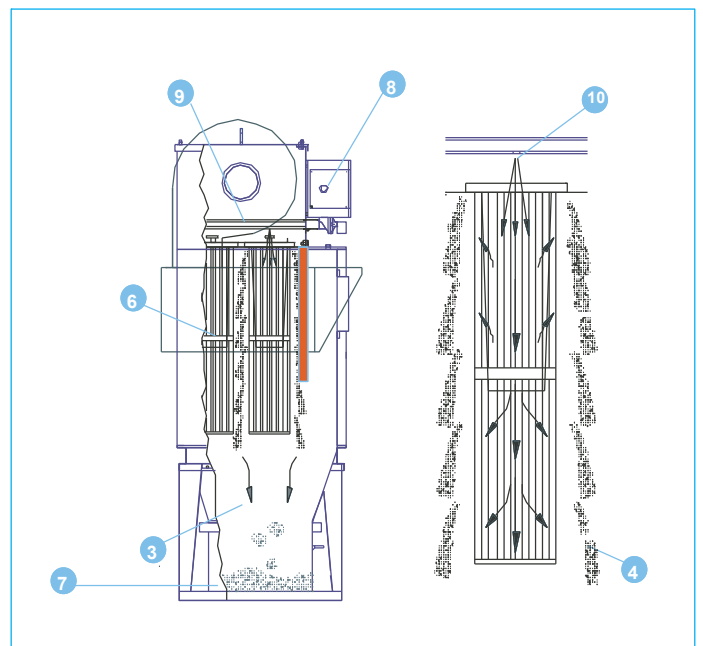

MJC Mini

Specification

Technical parameters:

- Robust construction in 2.5 mm thick steel, fully welded and painted
- Cartridge replacement from clean air side (Top removal)
- Normal maximum working temperature 80°C
- Normal maximum negative pressure 8000 Pa
- Normal maximum positive pressure 2000 Pa
- Normal compressed air pressure: 5 bar to 5.5 bar
- Cleaning controller in IP65 enclosure, supply voltage 230/220/110V
- Filter areas from 4 m² to 40 m²
- Three cartridge sizes
- Four standard cartridge materials.

Insertable units

- A space saving option where there is free space within the enclosure or vessel to be ventilated.
- Continuously or intermittently used storage or process vessels, with ventilation requirements up to approximately 3600 m³/h, handling dry powders or dusty materials.
- Transfer points in enclosed conveying systems.
- Mixing/blending vessels.
- Silo ventilation for most dry bulk materials, delivered mechanically or under pressure.

Cased units with flanged open base

- As for insertable units, but in situations where the cartridges must not protrude into the vessel.
- Ventilation / aspiration of enclosed conveyors, maintaining slight negative pressure to prevent leakage - MJC Mini directly mounted onto conveyor casing.
- Ventilation of displaced air from gravity filled process conveyors, for example grain and milled products in multi-bin storage and handling systems.
- Ventilation of sack tipping and bag splitting enclosures.

| Technical parameters | | | | | | | | |
|----------------------------|----------|----------|---------|----------|----------|----------|----------|----------|
| MJC Mini | 4/22/21* | 8/40/21* | 9/22/22 | 13/22/32 | 16/40/22 | 24/40/32 | 26/66/22 | 40/66/32 |
| Filter area m ² | 4.4 | 8 | 8.8 | 13.2 | 16 | 24 | 26.4 | 39.6 |
| Number of cartridges | 2 | 2 | 4 | 6 | 4 | 6 | 4 | 6 |
| Typical max. fan power kW | 0.75 | 0.75 | 1.1 | 1.1 | 2.2 | 2.2 | 2.2 | 3 |

*Open base filter without hopper and collection bin

Key example: MJC 4/22/21

| | |
|----|---|
| 4 | Filter area m ² |
| 22 | Cartridge of 2.2 m ² per unit (40 = 4 m ² and 66 = 6.6 m ²) |
| 21 | Number of rows (2) and number of cartridges by row (1) |

MJC Mini

Integral Fans & Fan Curves

To select a fan for use with an MJC filter unit, first determine the airflow volume, then the static pressure required at that airflow volume as follows:

- Determine the static pressure required for the application (hoods, ducts, cyclone if used).
 - Add 300Pa (30mm water) for the filter inlet resistance.
 - Add 1000Pa (100mm water) for bag resistance. For some "difficult" dust applications, add up to approx 2000Pa (200mm water).
 - Add 250Pa (25mm water) for a silencer, plus any outlet duct resistance.
- The sum of 1+2+3+4 above is the static pressure required from the fan.



Fan performance, with open outlet, at running speed 2900 Rpm.
Detachable fan used on MJC mini

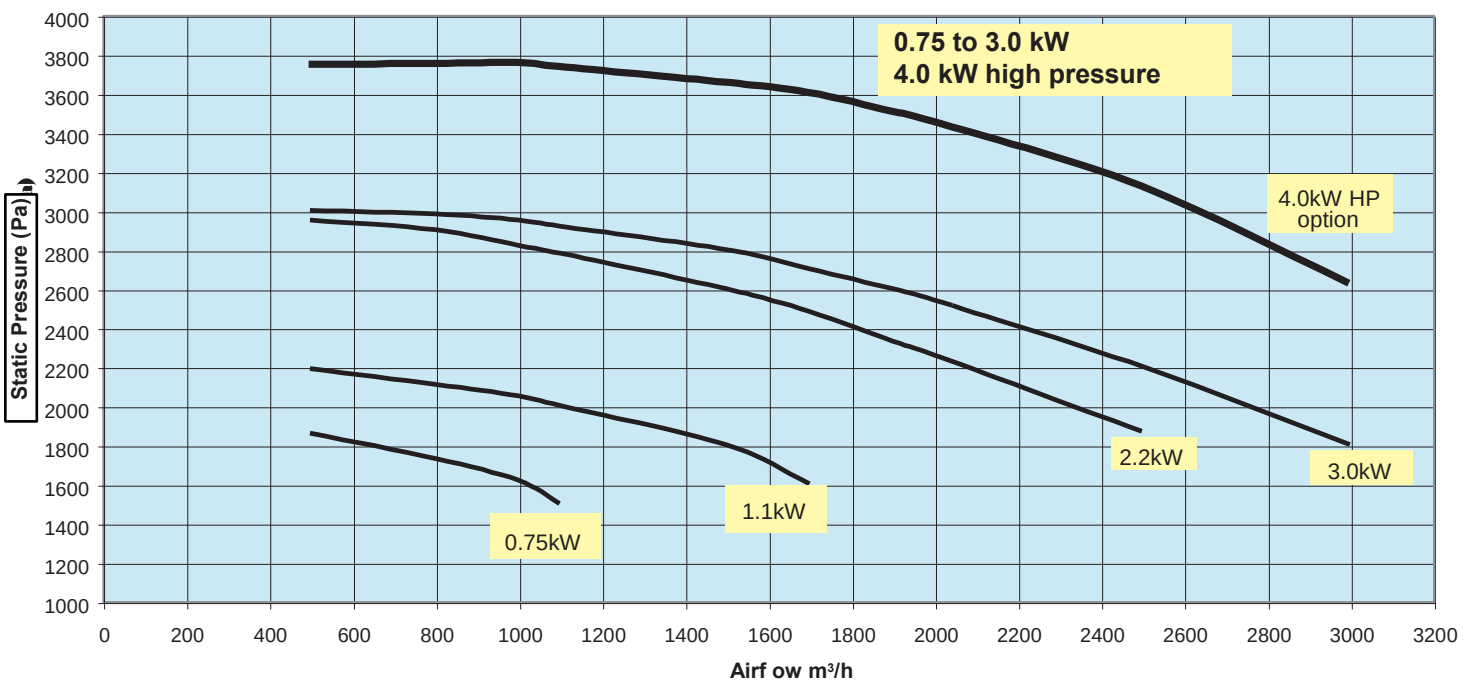

Other fan sizes available on request.

MJC Mini

Cartridge Materials

At the heart of every MJC cartridge filter is the UniClean® patent pleated cartridge element.



The overall dimensions, including pleat depth and spacing were designed uniquely for the MJC range and its smaller sisters MJC Mini and SiloSafe. Years of experience in many applications and the more recent introduction of the UniClean feature ensure maximum performance and long life.

Two sizes are available for the MJC range, **Type 40** with 4.0m² per element and **Type 66** with 6.6m² per element. The smallest version (illustrated) is the **Type 22** with 2.2m², available in the compact MJC Mini range.



Cross section CA100

Filter materials are:

- **CA100** high quality thermal bonded polyester pleated fabric as standard.
- **CA140**, similar to CA100, with adding metalized antistatic treatment.
- **CA190**, similar to CA100, with adding PTFE treatment for ease of dust release (sticky dust).
- **CA175** is a 80% cellulose, 20% polyester material available to special order.

Surface filtration

The filter media is typically around 1.7mm thick but contains many layers of random fibres. Filtration occurs at or very near the surface of the material and its efficiency (BIA class U,S,G,C) may be further enhanced by a surface layer of dust. For light dust loads, or very fine dust, it may be beneficial to pre-coat the filter by introducing used dust, or a special pre-coat material. Please ask for information.



Surface magnified x 20

UniClean® in detail

UniClean® provides more uniform cleaning air pressure over the whole cartridge during pulse cleaning (see figure 2). With conventional cartridges, the thick dust layer tends to form at the top section of the filter due to uneven and ineffective pulse cleaning and cause less filtration area.

The UniClean® concept overcomes this problem, dust accumulations being directed towards the middle of the cartridge. Another advantage is that it guarantees uniform cleaning pressure, as explained above.

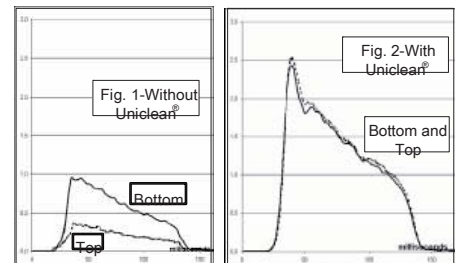

The internal air cleaning pressure is considerably higher than conventional cartridges with a similar reverse jet cleaning system. (Compare figures 1 and 2).

Effective cleaning reduces the number of cleaning impulses required. Consequently, the lifetime of the filter medium is longer and energy consumption for cleaning lower.

Patents

Germany: 19909075.0

International: PCT/EP00/01801

MJC Mini

Applications & Options

Cased units with bin. Optional castors and single phase for versatility and portability.

- General metalworking, dry processes including sawing, grinding, finishing, CNC machining extraction, sanding and shot blast.
- Pharmaceuticals tableting, laboratory mixing, non-hazardous powder mixing.
- Ceramics mixing booths, trimming and finishing booths, specialist small scale production.
- Ceramics educational establishments, work stations.
- Building products hand trimming and finishing processes, bathroom pottery.
- Stone Masonry sawing, cutting, sculpting, trimming and finishing
- Plastics machine cutting, sanding.
- Wood machining, sanding.

Options:

- Optional negative pressure up to 15000 Pa
- Optional positive pressure up to 5000 Pa
- Open base venting unit with or without fan
- Insertable version excluding dirty air chamber
- ATEX certified explosion relief ventilation for St1, St2, St3 dusts

Accessories:

- Silencer with weather cowl
- Secondary filter typically F7 or H14
- Explosion panel alarm switch
- Differential pressure indicator and alarm.



Soluzioni KOMSA per le vostre necessità di aspirazione

Vi mostriamo qui di seguito alcuni esempi di sistemi di aspirazione che fanno parte della nostra ampia gamma di prodotti.

Per maggiori informazioni potrete visitare il nostro sito internet: www.komsa.it

Bracci di aspirazione



Sistemi di aspirazione per gas di scarico veicoli



Elettroventilatori



Filtri



Filtri per impianti centralizzati



Filtri carrellati



Aspiratori industriali ad alta pressione



Arrotolatori per tubi e cavi



KOMSA

KOMSA ITALIA SRL Via A. Moro, 18 - 40068 S. LAZZARO DI SAVENA (BO)

Tel. +39.051.625.55.33 +39.051.625.60.61 Fax +39.051.625.51.88

www.komsa.it e-mail: info@komsa.it